

systemtronic
datasheet MSTFT03 y MPTFT03



General Description:

Series of central axis tables on which the supports for the different computer components are installed. The design of this table allows it to be incorporated into any environment, without forgetting that it is a functional and ergonomically functional place according to the standards set by the European Union.



Technical Characteristics:

The upper arm (A) is made of cold rolled metal formed by an oval tube 30x15mm and 120mm long, joined by welding at its base to a round tube of Ø50x49mm and at the other end to a round tube of Ø30x27mm. Both unions are covered with plastic trims. Available in a holder for the monitor (suitable for monitors that comply with VESA 75 or VESA 100) U-shaped wrapping the end of the arm and attached to these, using a bolt and two screws for fixing. With this we will achieve the desired rotary movement to guide the plasma monitor. Next to the U-shaped clamp, the clamping piece is available to the plasma monitor.

The keyboard arm (B) is made of cold rolled metal and is formed by oval tube 40x20 and 289mm long, joined by welding on its base to a round tube of Ø50x49mm and at the other end to a round tube of Ø30x60mm. Both unions are covered with plastic trims. They are arms designed to allow flat and free rotation with total stability that together with the board form a turning radius of 465mm.

The panels (B and C) are made of melamine MDF 13 mm thick with lacquered edges, 455x315mm (rectangular) and 715x440mm (shape) respectively, both fastened by screws.

Base of 530x510mm, with four non-slip to place the CPU with total security, giving even greater stability to the table. The ends of the tubes are protected with plastic ferrules.

Supplied with 5 wheels of polyamide-6 of 48mm in diameter, two of them with brake, allowing its free and simple displacement due to the stability of the table, and a fixed positioning free of unwanted movements.

MPTFT03

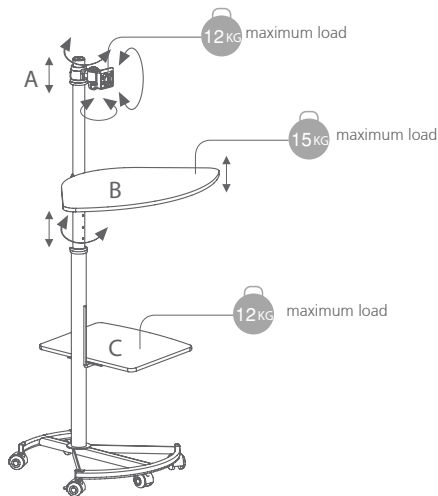

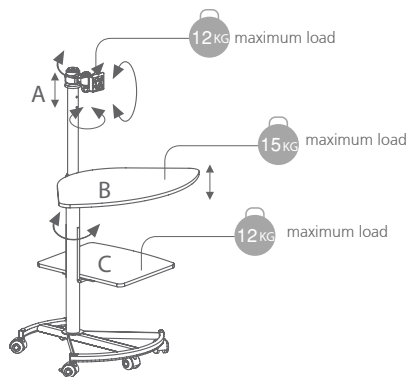

MSTFT03



mm · inches

Finishes:

STRUCTURE		TABLETOP		
				
white gloss	aluminum gloss RAL 9006	aluminum	white	cherry wood 3482
*Polyester paint				

Consult for special dimensions or any other modification.

Maintenance:

-Wood:

We recommend using a cloth or cleaning products for natural wood. Avoid using products containing solvents and/or alcohol.

-Polyester Paint:

For dry dirt (dust), use a damp cloth. For greasy/oily stains (fingerprints), wipe with a sponge with water and dishwashing liquid. Rinse with a damp cloth. Avoid using products containing solvents and/or pure ethyl alcohol.

-Aluminium-metal-glass-melamine-plastic:

We recommend using normal cleaning products for delicate surfaces. Alcohol, solvents and abrasive agents must be avoided.

Sustainability:

The used paints do not contain solvents, do not consume water and do not generate emissions or waste. The result is a lower environmental impact.

systemtronic _ MPTFT03 y MSTFT03

www.st-systemtronic.com

nacional@st-systemtronic.com · export@st-systemtronic.com

tel. 96-1852784 · fax.34-961854482

ASSOCIATED N°00320

GAIDIMME
INSTITUTO TECNOLÓGICO

METALÚRGICO, MUEBLE, MADERA, EMBALAJE Y AFINES



Calidad Controlada